

METAL BELLOW COUPLINGS

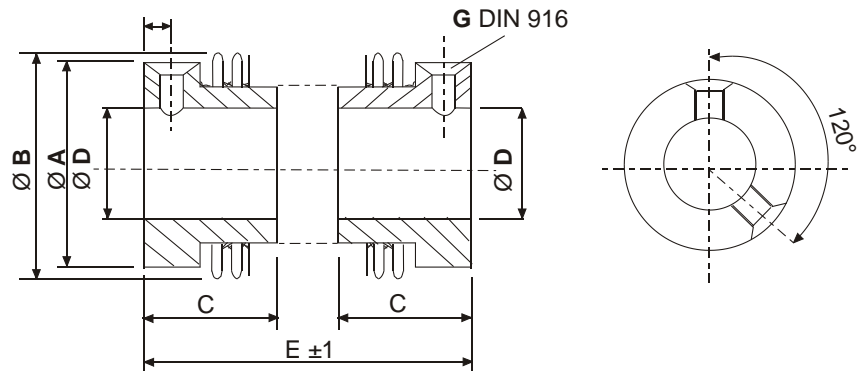

Misalignment:

Angular: $\pm 1,2^\circ$ to $\pm 2^\circ$ depending on version

Hub drillings:

D1 in compliance with customer in tolerance H7.D2: For the tolerance of shaft boring we recommend the clearance H8

Materials:

Collet-type clamp of aluminum alloy, expanding clamp DK/S 4 - 9 of brass, expanding clamp, DK/S 15 - 100 of steel, bellows of high grade steel

Couplings:

Couplings marked with * are stock goods at Scancon.
Other sizes can be delivered on request

TYPE	Ø A	Ø B	C	E(±1)	D1	D2	Order no.
EK 4/20	13	15	6	20	6	6	08400001*
EK 4/20	13	15	6	20	6	8	08400002*
EK 4/20	13	15	6	20	8	8	08400003*
EK 4/20	13	15	6	20	4	4	08400012
EK 15/25	19	19	12	25	6	10	08400005
EK 15/25	19	19	12	25	8	10	08400008
EK 15/25	19	19	12	25	10	10	08400011
EK 4/26	13	15	6	26	6	8	08400009*
EK 4/26	13	15	6	26	6	6	08400013
EK 20/33	21	24	12	33	6	10	08400007*

POLYAMIDCOUPLINGS



Technical data

		BSK 44 02	BSK 44 04
max. speed	min ⁻¹	10.000	10.000
max. torque	Ncm	20	100
max. radial offset	mm	±0,3	±0,3
max. angle offset	degree	±2,5	±3
max. axial offset	mm	±0,2	±0,2
torsion spring stiffness	rad	14	36
radial spring stiffness	mm	60	120
moment of inertia	g cm ²	1,1	6,5
max. clamping torque	Ncm	30	40
weight appr.	g	3,5	10
material :		Polyamide 6,6 fiberglass reinforced	

BSK 44 02

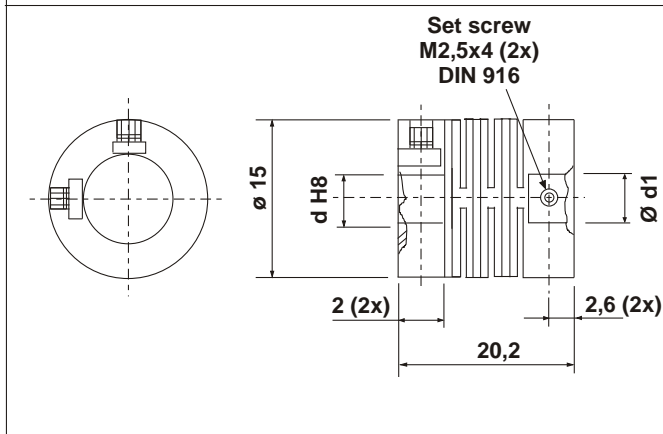

BSK 44 04

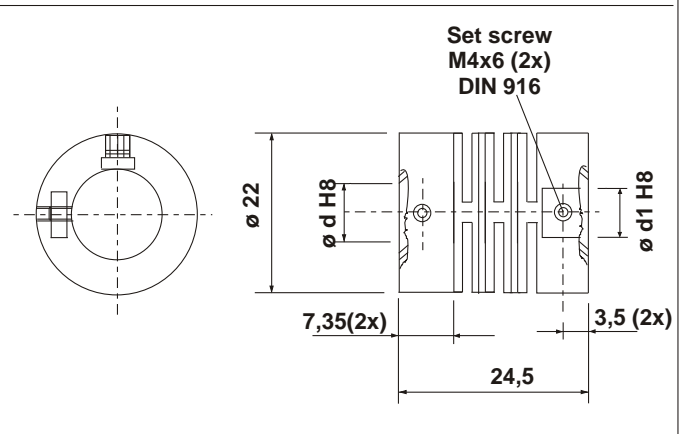

Couplings:

Couplings marked with * are stock goods at Scancon.
Other sizes can be delivered on request

TYPE	$\varnothing d$	$\varnothing d1$	Order No.
SKPS 1520	4	4	08410001*
BSK 440222	4	6	08410002*
SKPS 1520	6	6	08410003*
SKPS 2244	6	8	08410048*
BSK 440440	8	8	08410049

SPRINGCOUPLING

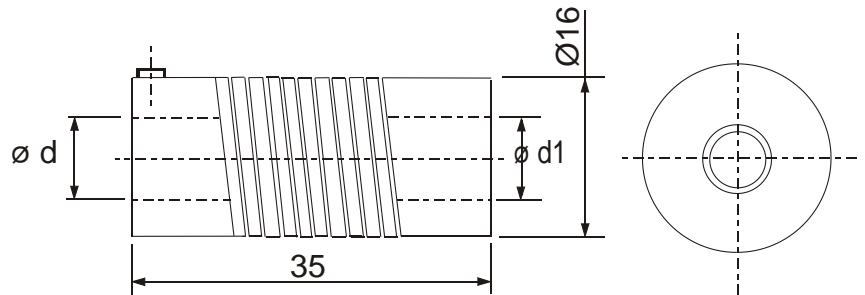

TYPE	$\varnothing d$	$\varnothing d1$	Order no.
K 402	6	6	08410007

Mountig clamps



Order no.

00145085

