



Type SCA36NA-SSI

- Absolute Encoder - Ø 36 mm
- Shaft - ø 6 mm
- Singleturn or Multiturn
- SSI Interface
- Binary or Gray Code
- Preset of Zero Position
- Choice of Counting Direction
- Enclosure Rating IP 65 or IP 67
- Supply voltage 5V or 9-30 V

Electrical Specifications

Encoder Type:	Absolute Multiturn
Singleturn Resolution:	13 bits (8192) step pr. revolution
Number of Revolutions:	12 bits (4096) revolutions 16 bits (65536) revolutions 20 bits (1048576) revolutions 24 bits (16777216) revolutions
Supply Voltage:	5 VDC ±5% or 9-30 VDC
Typical Current Consumption:	30 mA @ Vsup = 5V 25 mA @ Vsup = 10V 15 mA @ Vsup = 24V
Accuracy:	± 0,35°
Interface:	SSI (Synchronous Serial Interface)
Output Code:	Binary or Gray
Electrical Interface:	Differential (RS422) or single ended (TTL)
Clock Frequency:	100 kHz to 2 MHz
Counting Direction:	Increasing clockwise or increasing counter clockwise seen from shaft end of encoder
Electrical Protection:	Reverse polarity and output short circuit protected
Noise Immunity:	Tested to EN61000-6-2 : 2005 (industrial environments) Electromagnetic compatibility (EMC) and EN 61000-6-3 : 2007 (residential, commercial, and light-industrial environments) for Electromagnetic compatibility (EMC)

Mechanical Specifications

Material:	Housing: Aluminum Cap: Electroplated Steel or Aluminum Shaft: Stainless steel AISI 303
Weight:	Encoder: ~ 95 gr (3,35 oz) Cable: 50 gr / meter (1,76 oz / meter)
Bearing Life:	> 1,9 x 10 ¹⁰ revolutions at rated load
Shaft Speed:	6.000 rpm (max.)
Starting Torque:	< 0,005 Nm (0,708 oz-in) at 25° C
Mass Moment of Inertia:	1,05 gcm ² (1,49 x 10 ⁻⁵ oz-in-sec ²)
Shaft Loads:	Axial: 20 N (4,5 lbs) max. Radial: 20 N (4,5 lbs) max.

Environmental Specifications

Operating Temp.:	-40° to +85° C
Storage Temp.:	-40° to +85° C
Shock:	100 G @ 11 ms
Vibration:	10 G @ 10-2000 Hz
Bump:	10 G @ 16 ms (1000 x 3 axis)
Humidity:	98 % RH without condensation
Enclosure Rating:	IP 65 / Nema 4 (approx.) IP 67 / Nema 6 (approx.)

Connection Options

Cable:	8 leads (0,05 mm ² , 30 AWG) - Twisted pairs shielded
Connector:	M12 8-pin

Mechanical Dimensions

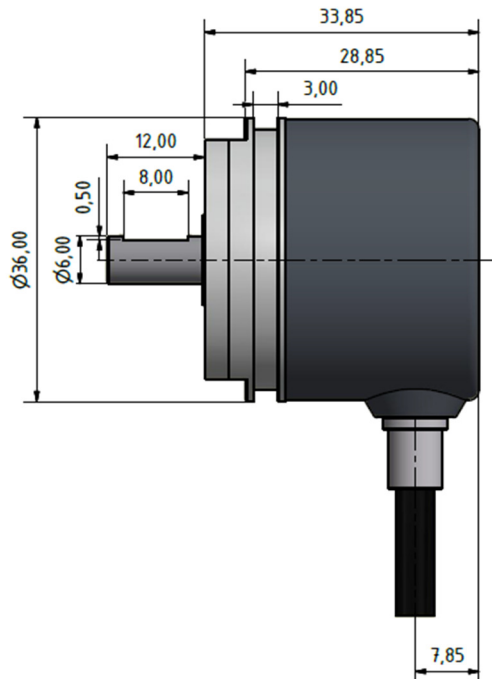

Standard Cable Gland

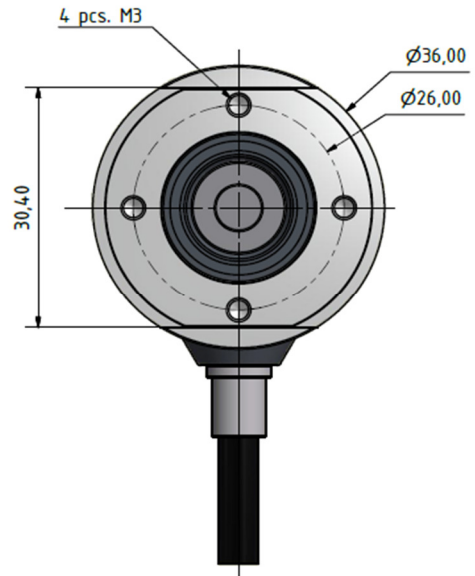

mm [inches]

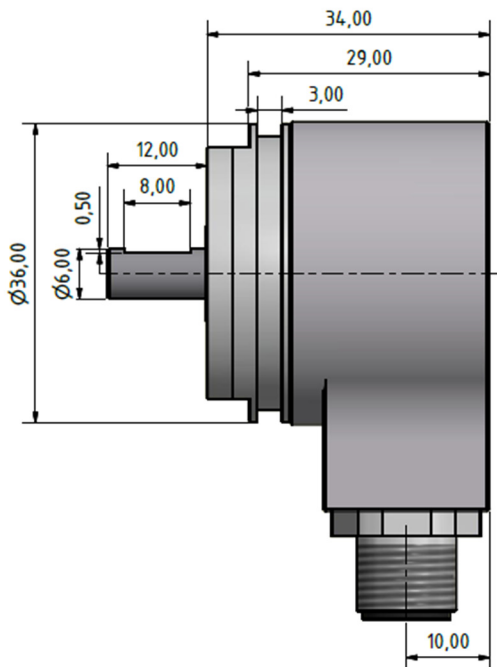

M12 Connector

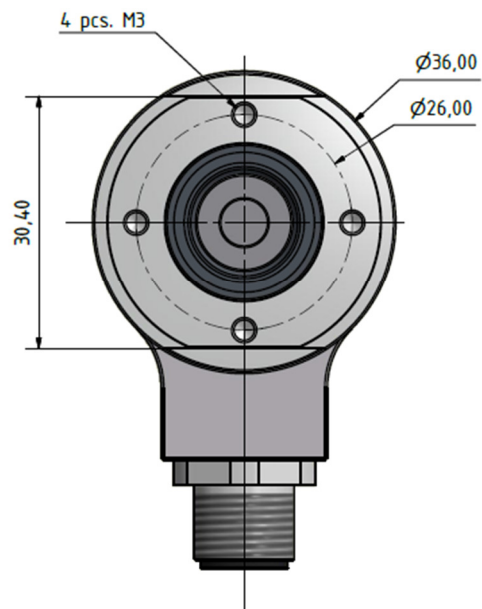

mm [inches]

Output Terminations

Signal	Cable
	Differential Input/output
Signal	Wire Color
CLK+	Green
CLK-	Yellow
DO+	Gray
DO-	Pink
Direction	Red
Preset	Blue
Vsup	Brown
GND	White

Shield connected to case ground

M12 Connector	
Differential Input/output	Single Ended Input/output
Pin Number	
3	3
4	Not Connected
5	5
6	Not Connected
8	8
7	7
2	2
1	1

Shield must be connected to connector housing

M12 Connector

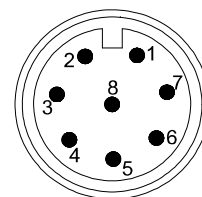

SSI Interface Timing

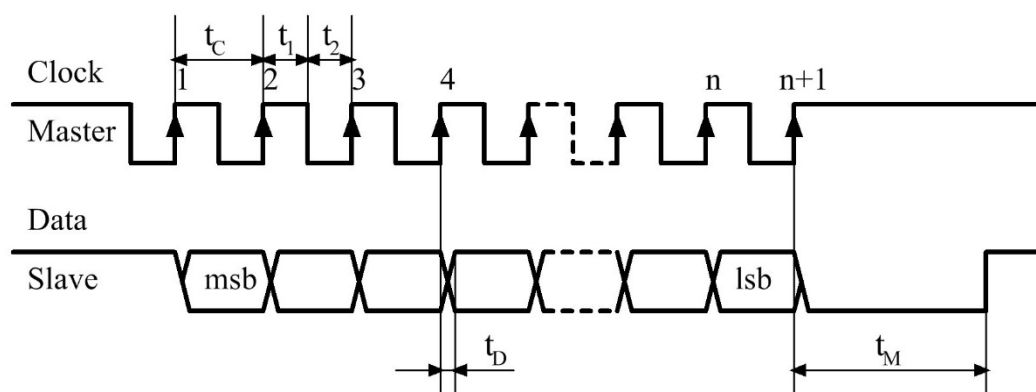

- msb = Most Significant Bit
- lsb = Least Significant Bit
- n = Total Number of Bits
- t_C = Clock Period = 0,5 to 10 μ Sec (100kHz to 2 MHz)
- t_1 = Clock High = 50% \pm 15% of Clock Period
- t_2 = Clock Low = 50% \pm 15% of Clock Period
- t_D = Clock to Data Valid = Max. 100 nSec
- t_M = Monoflop Time = 20 \pm 3 μ Sec

Implementation

During the initial set-up and installation of the encoder, it is possible to set the direction of rotation and preset the encoder to zero.

Setting of Direction.

The connection designated "Direction" is used to set the direction of rotation. Notice, that the encoder must not be powered when the direction of rotation is set/changed. Notice also, that the encoder will change its position value when the direction of rotation is changed. Direction of rotation is viewed on the shaft end of the encoder.

Voltage Level on Input	Function
High: V_{sup} or $V_{sup}/2 \leq V_{in} \leq V_{sup}$	Encoder Increasing on Counter Clockwise Rotation
Low: Input not connected or $0V \leq V_{in} \leq V_{sup}/2$	Encoder Increasing on Clockwise Rotation

Preset to Zero

The connection designated "Preset" is used to preset the encoder to zero. Notice, that the encoder must be powered when it is preset to zero.

Voltage Level on Input	Function
High: V_{sup} or $V_{sup}/2 \leq V_{in} \leq V_{sup}$	Encoder Value is set to Zero
Low: Input not connected or $0V \leq V_{in} \leq V_{sup}/2$	Inactive

The encoder will be held at zero as long as the line is high, even though the shaft is turned. The line must be high for at least 100 mSec. for the preset to take effect. The new zero point will be stored permanently in the encoder.

