



Type SCH94

- Hollow Shaft Encoder - \varnothing 94 mm
- Hollow bore - \varnothing 12 mm, \varnothing 16 mm or \varnothing 17 mm
- IP 66 (IP 65 & IP 67 options)
- chromitAL TCP passivation for Offshore Applications
- Built-in Transient Suppression Module

Electrical Specifications

Code:	Incremental
Resolution:	1 to 10,000 ppr (pulses per revolution)
Supply Voltage:	5V or 9 - 30V **
Current Consumption:	45 mA max. (no load)
Supply Voltage and Output Specifications for various Output Standards:	TTL: $V_{sup} = 5V \pm 10\%$ $V_{high} \geq 4.3V @ I_{out} = -16 mA$ $V_{low} \leq 0.5V @ I_{out} = 16 mA$
	RS422: $V_{sup} = 5V \pm 10\%$ Min. diff. load (Z_o): 100 Ω $V_{diff.} \geq 2.9V @ Z_o = 100 \Omega$ $V_{high} \geq 3.8V @ Z_o = 100 \Omega$ $V_{low} \leq 0.9V @ Z_o = 100 \Omega$
	HTL: $V_{sup} \geq 9V - 30V$ $V_{high} \geq V_{sup} - 1.8V @ I_{out} = -20mA$ $V_{low} \leq 0.8V @ I_{out} = 20 mA$
Output Current:	30 mA max. load per output channel **
Frequency Response:	300 kHz max.; 100 kHz with TSM **
Output Format:	Two channel (A, B) quadrature with Index (Z) and complementary (A-, B-, Z-) outputs
Phase Sense:	A leads B clockwise (CW) from the shaft end of the encoder
Index:	Gated with Channels A and B high
Accuracy:	+/- 0.8 arc-min.
Output:	OL7272 Line Driver HTL, TTL and RS422 compatible
Electrical Protection:	Output short circuit, reverse polarity (MS output only) and transient surge protected through built-in protection module (see TSM details on website)
Noise Immunity:	Tested to EN61000-6-2 : 2005 (industrial environments) and EN 61000-6-3 : 2007 (residential, commercial, and light-industrial environments) for Electromagnetic compatibility (EMC)

**= It is recommended user not to combine max. Value for all 3 parameters

Mechanical Specifications

Material:	Housing: Aluminum Cap: Aluminum Hollow shaft: Stainless Steel (AISI 303)
Weight:	Encoder: approx. 925 gr. (32.65 oz)
Bearing Life:	> 1.9×10^{10} revolutions at rated load
Shaft Speed:	2,200 rpm continuous (max.) IP 66 (IP 67 option) 3,000 rpm continuous (max.) IP 65 (option)
Starting Torque:	< 0.1 Nm (14.16 oz-in) at 25° C
Mass Moment of Inertia:	31 gcm ² (4.39×10^{-4} oz-in-sec ²)
Shaft Loads:	Axial 200 N (45 lbs) max. Radial 400 N (90 lbs) max.

Environmental Specifications

Operating Temperature:	-40° to +85° C
Storage Temperature:	-40° to +85° C
Shock:	100 G / 11 ms
Vibration:	(10-2000 Hz) / 10 G
Bump:	10 G - 16 ms (1000 x 3 axis)
Humidity:	98 % RH without condensation
Enclosure Rating:	IP 66 / Nema 6 (approx.) IP 67 / Nema 6 (approx.) option IP 65 / Nema 4 (approx.) option chromitAL TCP passivation
Non-conductive Hollow Bore:	Non-conductive ceramic insert for shaft insulation; up to 2.5 kV

Connection Options

Cable:	8 leads (0.75 mm ² , 19 AWG) twisted pairs; shielded; halogen free
Connectors:	9-lead terminal blocks (inside cap) M20 cable gland (fits cable \varnothing 8 - 14 mm) 12-pin M23 connector

Output waveform

Disk Resolutions (pulses per revolution)

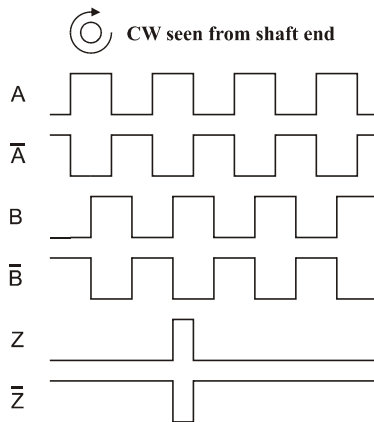

50	746	1024	2048	2500
3072	4096			

Other Options on request
 Pulses per revolution,
 Min. 1 – Max. 10.000

Channel tolerance 180 e° +/- 36 e°
Phase difference tolerance 90 e° +/- 18 e°
Z channel tolerance 90 e° +/- 18 e°

Mechanical Dimensions

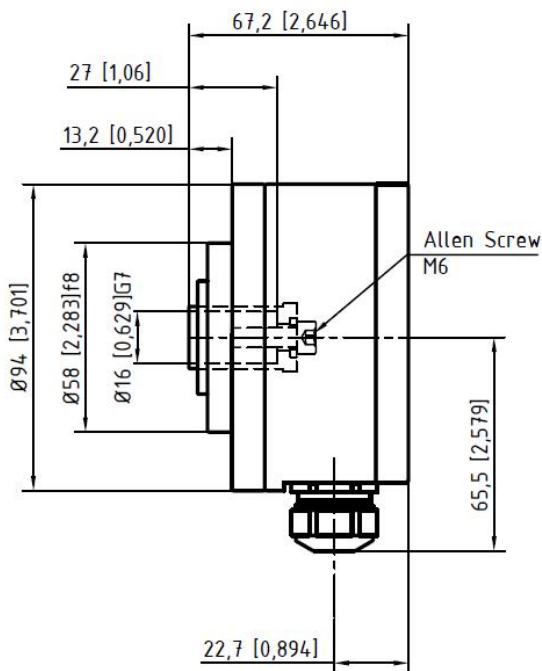

Standard Cable Gland

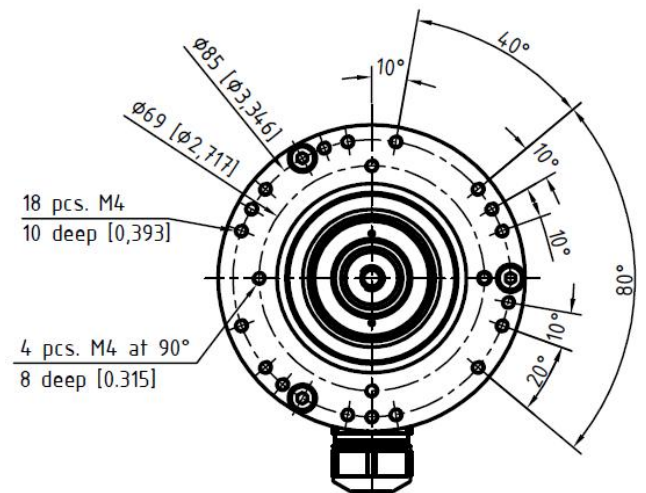

mm (inches)

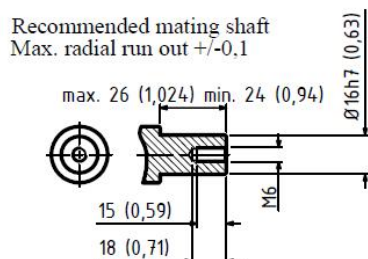

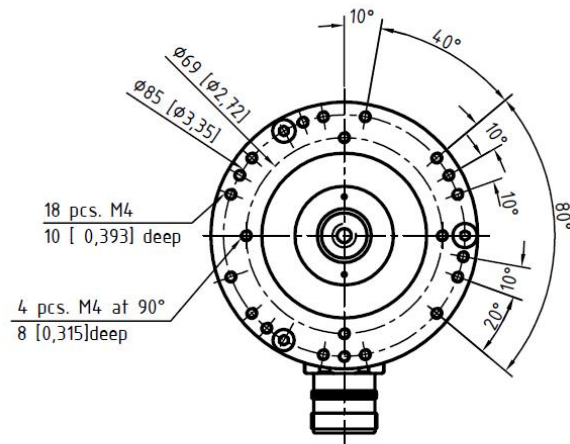
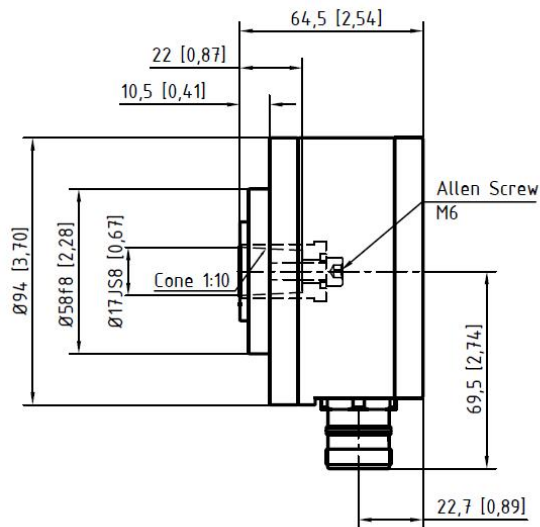

Recommended mating shaft
 Max. radial run out +/-0,1

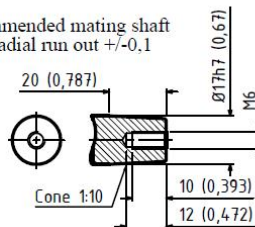

M23 connector

mm (inches)

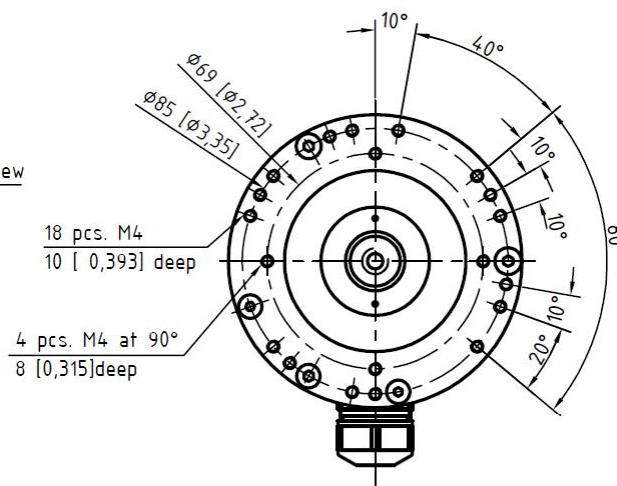
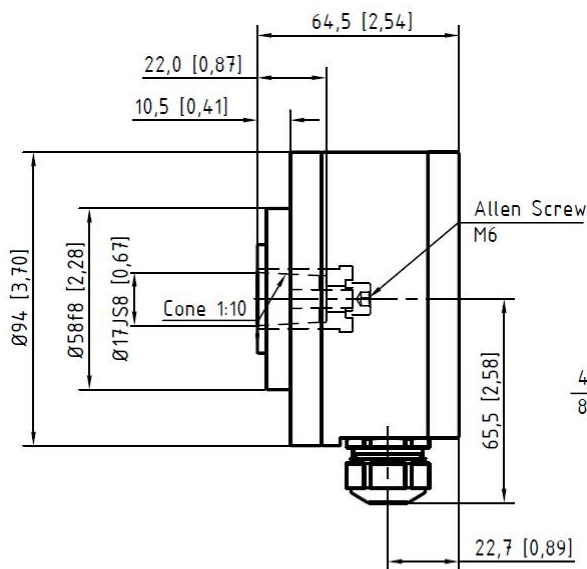

Recommended mating shaft
 Max. radial run out +/-0,1

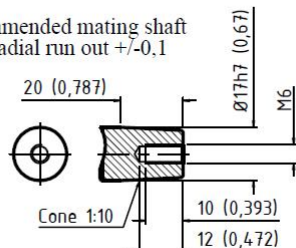

Standard Cable Gland

mm (inches)

SCH 94 Ø17

Output Terminations

Removable End Cap

Position	Terminal Block	
	Standard Output	Differential Output
	Channel	Channel
1	Shield	Shield
2	Vsup	Vsup
3	GND	GND
4	A	A
5	*	A -
6	B	B
7	*	B -
8	Z	Z
9	*	Z -

* Do not attach any wires to terminal block

GND = Circuit Ground

Shield = Case Ground

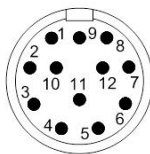

M23 Connector	
Pin	Channel
1	B -
2	N/C
3	Z
4	Z -
5	A
6	A -
7	N/C
8	B
9	N/C
10	GND
11	N/C
12	Vsup

Connect Cable Shield to mating
Connector Housing

GND = Circuit Ground

3 pcs: Terminal block

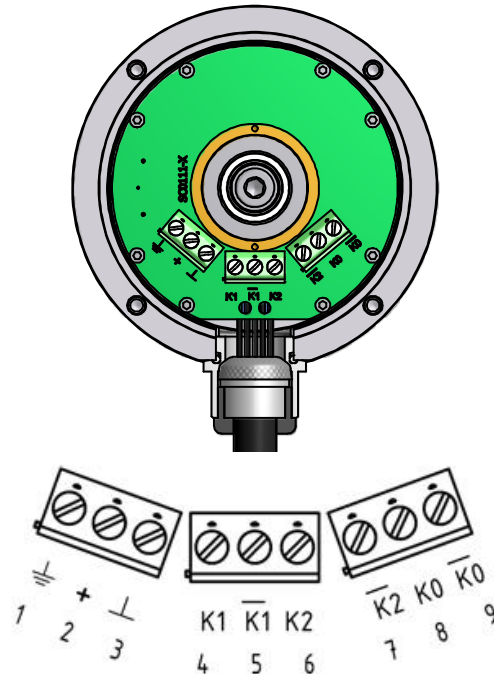

Standard Cable

Channel	Standard Output	Differential Output
	Wire Color	Wire Color
A	Pink	Pink
A -	Gray*	Gray
B	Green	Green
B -	Yellow*	Yellow
Z	White	White
Z -	Brown*	Brown
Vsup	Red	Red
GND	Blue	Blue

* Gray, Yellow, and Brown are internally
connected to Circuit Ground

GND = Circuit Ground

Ordering Code

Example: SCH94 – 3072 – MS – 17 – 20 – 66 – 00 – CG1

Type



Pulses per Revolution

See table

Output

HTL	9V – 30V	MS
TTL and RS-422	5V only *	MT

* *Not Reverse Polarity Protected*

Hollow Shaft Dia.

Hollow Shaft Length

IP Rating

IP 65	65
IP 66	66
IP 67	67

Cable Length

Standard	<i>1 meter is standard</i>	01
Specify length		XX
No cable	<i>Cable Gland or Connector</i>	00

Cable, Cable Gland, or Connector

12 mm x 27 mm	12 - 27
16 mm x 27 mm	16 - 27
17 mm x 20 mm <i>1:10 cone shape</i>	17 - 20

<u>Cable</u>	
Side (radial) takeout	S
<u>Cable Gland (no cable) - Blind Hollow Bore only</u>	
Fits Ø8 – 11 mm cable	CG1
Fits Ø11 – 14 mm cable	CG2
<u>Connector</u>	
M23 12-pin <i>clockwise pins</i>	CW
M23 12-pin <i>counterclockwise pins</i>	CCW

Other options on request:
Please contact Scancon A/S