

## Type SCH68SUB

- 68 mm (2.68") Servo mount
- Hollow bore Ø 10 mm to Ø 1 inch
- Shaft Loads to 100 N (22.5 lbs)
- IP 68 (permanent 6000m)

Electrical Specifications	
<b>Code:</b>	Incremental (magnetic)
<b>Resolution:</b>	25 to 4096 ppr (pulses per revolution)
<b>Supply Voltage:</b>	4,5 Vdc to 30 Vdc max. (35 mA max. - no load)
<b>Output Voltage:</b>	Low: 500 mV max. at 10 mA High: (V <sub>in</sub> - 0,6 V) at -10 mA (V <sub>in</sub> - 1,3 V) at -25 mA
<b>Output Current:</b>	30 mA max. load per output channel
<b>Max. Output Frequency:</b>	200 kHz
<b>Output Format:</b>	Two channel (A, B) quadrature with Index (Z) and optional complementary (A-, B-, Z-) outputs
<b>Phase Sense:</b>	A leads B clockwise (CW) from the mounting end of the encoder
<b>Index:</b>	Gated with Channels A and B high
<b>Accuracy:</b>	0,35 °
<b>Outputs:</b>	ASIC Standard or Differential
<b>Electrical Protection:</b>	Output short circuit protected Reverse polarity protected Transient Suppression Module
<b>Noise Immunity:</b>	EN61000-6-2: 2005 (industrial environments) Electromagnetic compatibility (EMC) EN 61000-6-3: 2007 (residential, commercial, and light-industrial environments) for Electromagnetic compatibility (EMC)

Mechanical Specifications	
<b>Material:</b>	Housing: AISI 316L Cap: AISI 316L Hollow Shaft: AISI 316L
<b>Weight:</b>	Encoder: Approx. 2200 g (77.601 oz)
<b>Bearing Life:</b>	> 1.9 x 10 <sup>10</sup> revolutions at rated load
<b>Shaft Speed:</b>	2000 rpm max.
<b>Starting Torque:</b>	< 0.05 Nm (7.08 oz-in) at 25° C IP 68
<b>Mass Moment of Inertia:</b>	1400 gcm <sup>2</sup> (19,82 x 10 <sup>-8</sup> oz-in-sec <sup>2</sup> )
<b>Shaft Loads:</b>	Axial 100 N (22.50 lbs) max. Radial 100 N (22.50 lbs) max.

Environmental Specifications	
<b>Operating Temperature:</b>	-10° to +70° C
<b>Storage Temperature:</b>	-40° to +85° C
<b>Shock:</b>	100 G @ 11 ms
<b>Vibration:</b>	10 G @ 10-2000 Hz
<b>Bump:</b>	10 G @ 16 ms (1000 x 3 axis)
<b>Enclosure Rating:</b>	IP 68 / Permanent submersion to 6000 m

Connection Options	
<b>Connectors:</b>	SUBCON 4pin male MCBH4MSS SUBCON 8pin male MCBH8MSS

## Output waveform

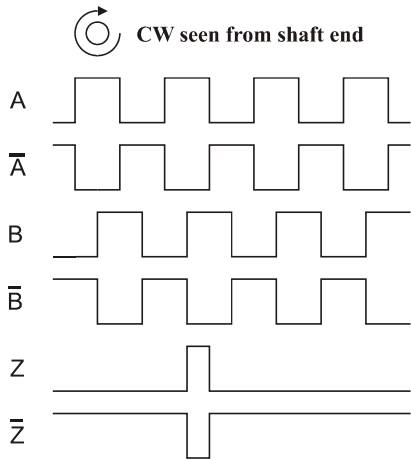

Channel tolerance       $180^\circ \pm 36^\circ$   
 Phase difference tolerance     $90^\circ \pm 18^\circ$   
 Z channel tolerance         $90^\circ \pm 18^\circ$

## Table 1. Disk Resolutions (pulses per revolution)

25	50	100	200	256
300	400	500	512	1000
1024	2048	4096		

## Mechanical Dimensions

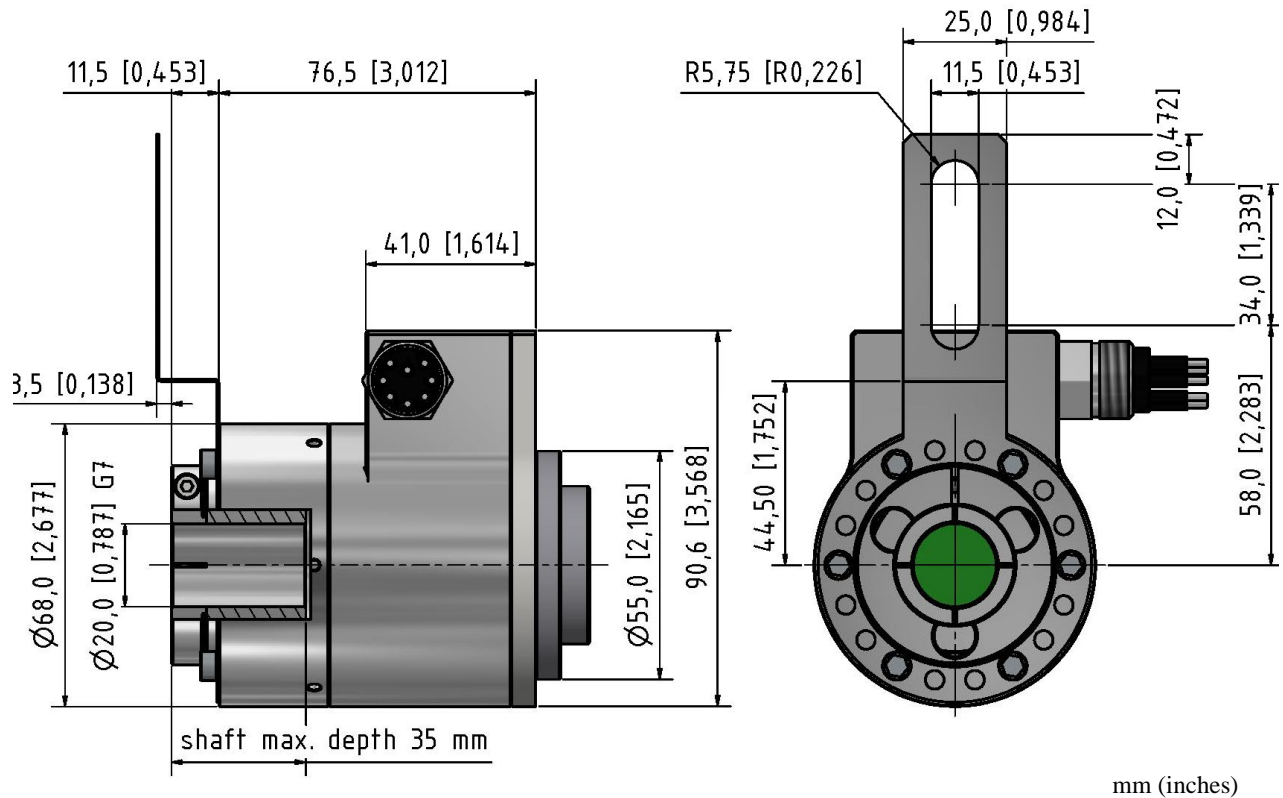

## Output Terminations – Connectors:

SUBCON 4 Pin	
Standard Output	
Pin	Channel
1	Circuit ground
2	B
3	Vsup
4	A

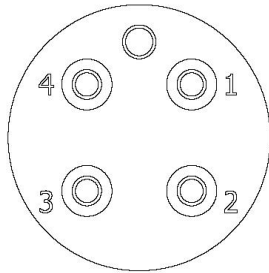

SUBCON 8 Pin	
Differential Output	
Pin	Channel
1	Z-
2	Z
3	B-
4	Vcc
5	B
6	A
7	A-
8	GND

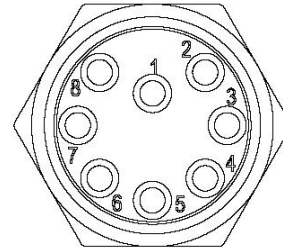

## Ordering Code

**Example: SCH68SUB -01M - 1024 - D - 20 x 35 - 68 - 00 - S - C8 - S1**

SCH68SUB-01M -  -  -  -  -  -  -  -  -

1                    2                    3                    4                    5                    6                    7                    8

**1. Resolutions**

See Table 1.

**3. Hollow Shaft (diameter)**

20 mm .....**20 x 35**

*Other hollow shaft diameters  
may be requested*

**5. Cable Length**

No Cable ..... **00**

**7. Connector**

SUBCONN 4 .....**C4**  
 SUBCONN 8 .....**C8**

*Female Mating Connector  
is not included*

**2. Output**

Standard 4,5V to 30V ..... **N**  
 Differential 4,5V to 30V .....**D**

*Build-in Transient Suppression  
Module (TSM). See Scancon  
Website for information*

**4. IP Rating**

IP 68 ..... **68**

**6. Cable Takeout**

Side (Standard) .....**S**

**8. Spring Coupling**

1 hole p/n 80131017 ... **S1**  
 2 holes p/n 80131067 ... **S2**  
 1 hole p/n 80132464 .... **S3**  
 2 holes p/n 80131062 ....**S4**

*See Accessories data sheet for Anti-rotation Springs/Torque Arm options*