

## EXAG – Ethernet/Modbus



- Hollow Shaft Encoder - Ø 78 mm
- Hollow Shaft: Ø 14 mm and Ø 16 mm
- Ethernet - TCP/IP and MODBUS TCP communication protocols
- Resolution up to 30 bits
- Non-removable end cap – delivered with cable
- ATEX, IECEx, and EAC Ex certified

| Electrical Specifications     |   |
|-------------------------------|---|
| <b>Code:</b>                  | Absolute - Binary   |
| <b>Interface:</b>             | Ethernet Modbus TCP,  |
| <b>Profile</b>                | TCP/IP, -UDP, MODBUS/TCP  |
| <b>Resolution:</b>            | Max. 14 bit (16384) revolutions<br>Max. 16 bit (65536) steps per rev. |
| <b>Device Addressing:</b>     | Programmable IP address and Network parameters                        |
| <b>Transmission Rate:</b>     | 10/100 Mbit   |
| <b>Supply Voltage:</b>        | 10 to 30 Vdc (absolute limits)<br>According to EN 50178               |
| <b>Current Consumption:</b>   | Max. 230 mA with 10 Vdc<br>Max. 100 mA with 24 Vdc                    |
| <b>Power Consumption:</b>     | Max. 2.5 watts  |
| <b>Accuracy (INL):</b>        | ±0.0220° (14-16 bit),<br>±0.0439° (≤13 bit)                           |
| <b>MTTF:</b>                  | 134 years @ 40°C  |
| <b>Electrical Protection:</b> | Reverse polarity and over-voltage-peak protection                     |
| <b>Noise Immunity:</b>        | EN61000-6-2   |
| <b>Emitted Interference:</b>  | EN 61000-6-4  |

| Electrical Connection   |        |
|-------------------------|--------|
| <b>Cable Outlet</b>     | Radial |
| <b>Connection Type</b>  | Cable  |
| <b>Min. Bend Radius</b> | 103 mm |

| Mechanical Specifications            |   |
|--------------------------------------|---|
| <b>Material:</b>                     | Housing: Aluminum or Stainless Steel<br>Cap: Aluminum or Stainless Steel<br>Hollow Shaft: Stainless Steel |
| <b>Weight:</b>                       | Aluminum: ~ 1600 gr (56,44 oz)<br>Stainless Steel: ~ 3100 gr (109,35 oz)                                  |
| <b>Bearing Life:</b>                 | > 1,9 x 10 <sup>10</sup> revolutions at rated load  |
| <b>Hollow Shaft Speed:</b>           | 6.000 rpm (max.) IP 64<br>3.000 rpm (max.) IP 65, IP 66, IP 67  |
| <b>Starting Torque:</b>              | ≤ 0,01 Nm at 25° C (no seal)<br>≤ 0,03 Nm at 25° C (with seal)  |
| <b>Rotor Mass Moment of Inertia:</b> | 42 gcm <sup>2</sup> (5,95 x 10 <sup>-4</sup> oz-in-sec <sup>2</sup> )                                     |
| <b>Hollow Shaft Loads:</b>           | Axial: 60 N (13,50 lbs) max.<br>Radial: 80 N (17,98 lbs) max.   |

| Environmental Specifications |   |
|------------------------------|---|
| <b>Operating Temp.:</b>      | -40° to +70° C  |
| <b>Storage Temp.:</b>        | -40° to +70° C  |
| <b>Shock:</b>                | 100g @ 11 ms  |
| <b>Vibration:</b>            | 10g @ 10-2000 Hz  |
| <b>Bump:</b>                 | 10g @ 16 ms (1000 x 3 axis)   |
| <b>Humidity:</b>             | 98 % RH without condensation  |
| <b>Enclosure Rating:</b>     | IP 64 / Nema 4 (approx.)<br>IP 65 / Nema 5 (approx.)<br>IP 66 / Nema 6 (approx.)<br>IP 67 / Nema 6 (approx.)<br>IP 68 (1hour/1 meter) / Nema 6P (approx.) |

## Certifications

|                |   |
|----------------|---|
| <b>ATEX:</b>   | Certificate No.: ITS09ATEX16867X<br>II 2 G Ex db IIC T5 Gb II 2 D Ex tb IIIC T100°C Db -40°C ≤ Ta ≤ +70°C         |
| <b>IECEX:</b>  | Certificate No.: IECEX ITS 10.0016X<br>Ex db IIC T5 Gb, Ex tb IIIC T100°C Db -40°C ≤ Ta ≤ +70°C                   |
| <b>EAC Ex:</b> | НАННО «ЦСВЭ» No. EAЭС RU C-DK.AA87.B.00266/19<br>1Ex db IIC T5 Gb X, Ex tb IIIC T100°C Db X -40°C < T.amb < +70°C |

## Interface

### Protocols

Depending on which communication protocol option is chosen, the communication is based on either Ethernet – TCP/IP, UDP, or Modbus/TCP at data rates of 10 Mbps or 100 Mbps. TCP/IP stacks are available in all common operating systems. A data exchange in heterogeneous networks is possible by using the IP protocol. The control system sends commands to and receives data from the Encoder by the exchange of commands in ASCII text. Java Applets providing a graphical user interface (GUI) and documentation is provided on a Web server integrated in the Encoder for convenient configuration and diagnosis. Based on http, html and Java applets the GUI and all documents can be displayed on all common web browsers. In addition to the encoder parameters all necessary network parameters, like the IP- address, can be set. All parameters are saved in a non-volatile memory so that the configuration is available promptly after a restart. Another feature of the web server is the optional output of messages via the SMTP protocol. In this way parameters and diagnosis messages can be sent by e-mail.

As UDP does not provide a secure transmission of data, only polling the encoder and receiving position values are available in the UPD mode.

|                     |   |
|---------------------|---|
| <b>ModBus / TCP</b> | The data will be transported in the TCP-Frame. For detailed information's see the manual or on <a href="http://www.modbus.org">www.modbus.org</a> .   |
| <b>IP</b>           | A data exchange in heterogeneous networks is possible by using the well-known internet protocol "IP". The universal IP addressing simplifies the implementation of communication processes significantly. |
| <b>TCP / UDP</b>    | TCP Protocol assures an error free data transmission.<br>For an enhanced real-time performance, the UDP Protocol can be used as an alternative  |
| <b>http</b>         | Via http, a common web browser can be used for read out, configuration and diagnosis of the encoder with version A1.  |
| <b>smtp</b>         | Via smtp protocol, messages of the encoder can simply be sent by e- mail with version A1.   |

## Programmable Parameters

The encoder is able to provide three different kinds of output data: the position value, a velocity value, and a time stamp. These can be used in arbitrary combinations. The following parameters can be modified:

| Parameter  | Comment   |
|--|---|
| Used Scope of Physical Resolution<br>(Parameter 1) | Specifies the part of the physical resolution used for the encoder in physical steps. If e.g. for an encoder with a resolution of 8,192 steps per revolution 16,384 is chosen, the encoder will count 8,192 steps per revolution (if “Total scaled resolution” is set to the same value as “Used scope of physical resolution”) and start with zero again after 2 revolutions. If this value is not set to a value which results in an integer division with the total physical resolution, the encoder value will jump to zero when passing the physical zero point. |
| Total Scaled Resolution<br>(Parameter 2)           | Specifies the scaled resolution which is used over the area of physical steps defined by “Used scope of physical resolution”. If e.g. the encoder is set as described above and “Total scaled resolution” is set to 10, the encoder will count 10 steps over the physical steps defined with “Used scope of physical resolution”, i.e. 5 steps per revolution.  |
| Code Sequence                                      | The parameter Code Sequence (Complement) determines whether the output code increases or decreases when the axis is turned clockwise.   |
| Preset Value                                       | The preset value is the desired output value for the actual position of the axis. The actual output value will be set to this preset value.   |
| Offset Value                                       | This variable makes it possible to directly change the offset calculated and set by the preset function.  |

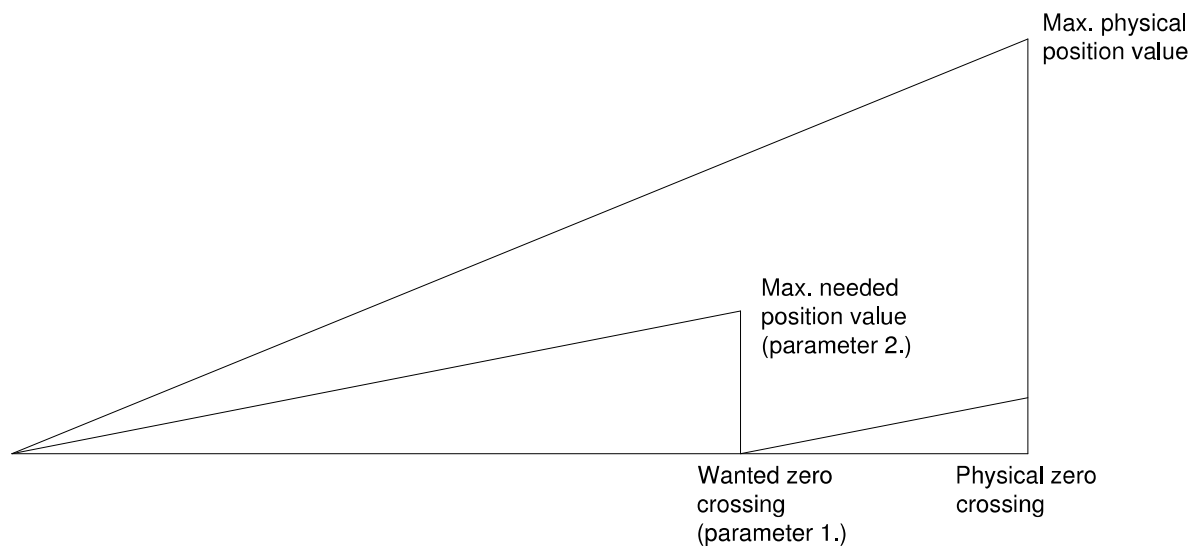

The integrated web server of the encoder contains different web pages for information purposes and to parameterize the encoder. The html page for configuration and diagnostics is: <http://198.100.100.54/status/status.html>

## Face Mounts

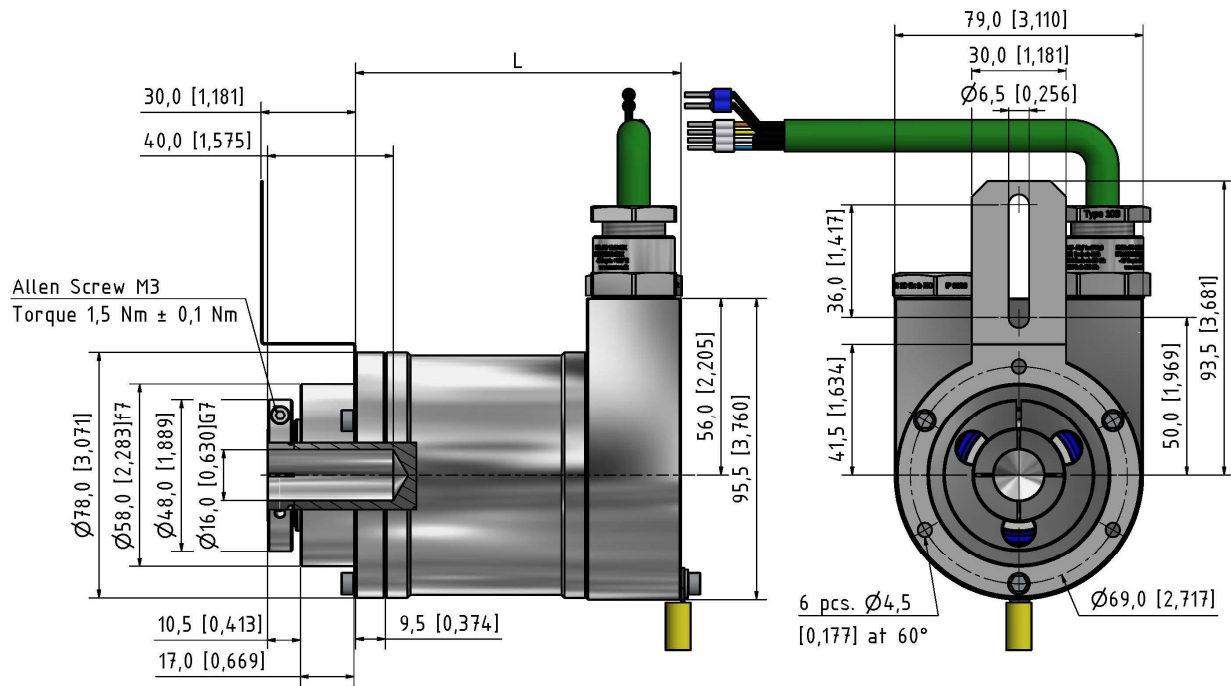

**Face Mount B**  
*Clamping Flange*

mm (inches)

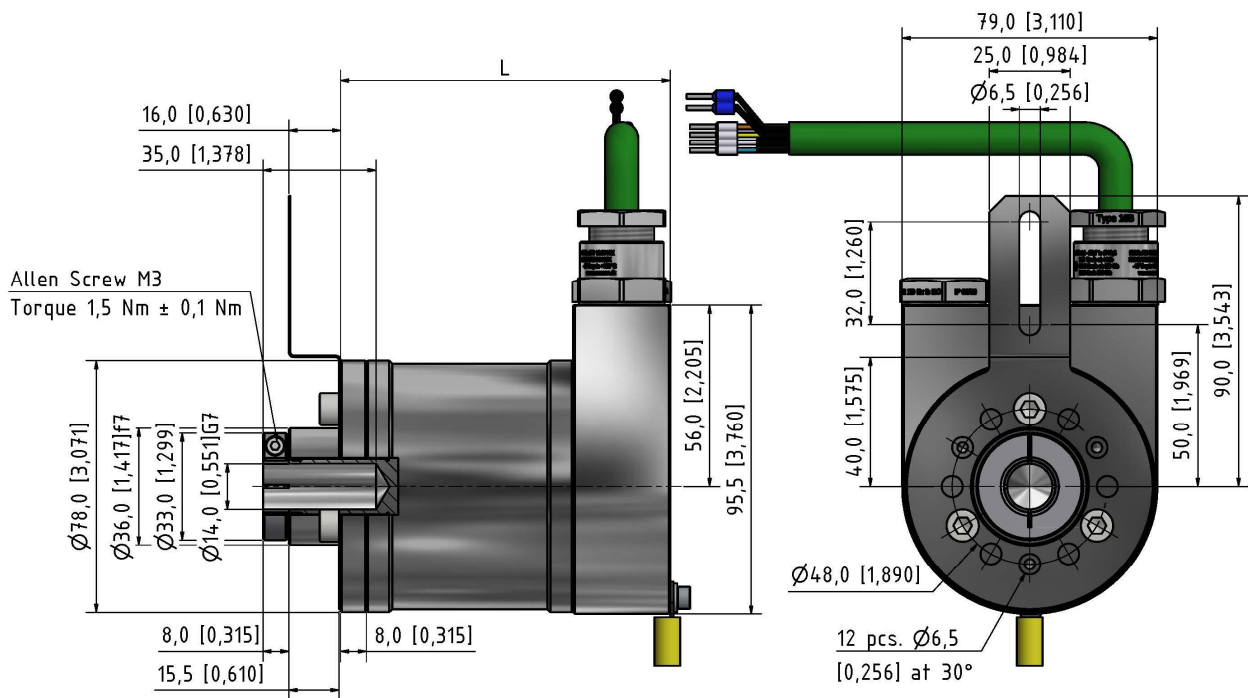

**Face Mount C**  
*Clamping Flange*

mm (inches)

## End Caps with Cable

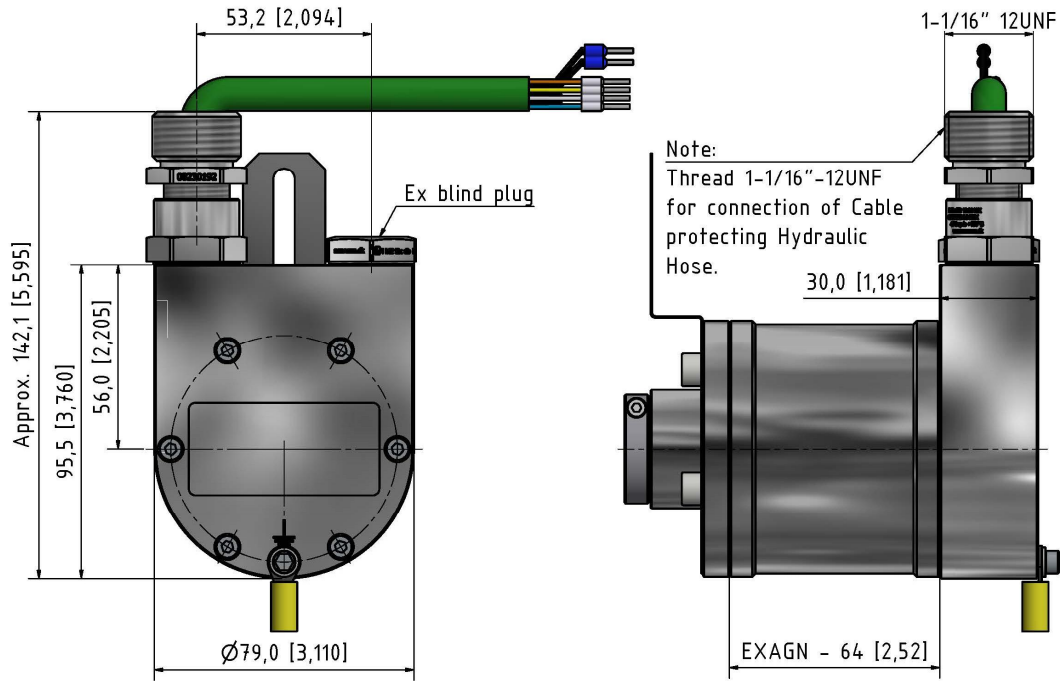

### Side Cable Takeout - EGA

mm (inches)

*Ex d certified cable gland included*

*For use with cable-protecting hose (NBR composite or similar)*

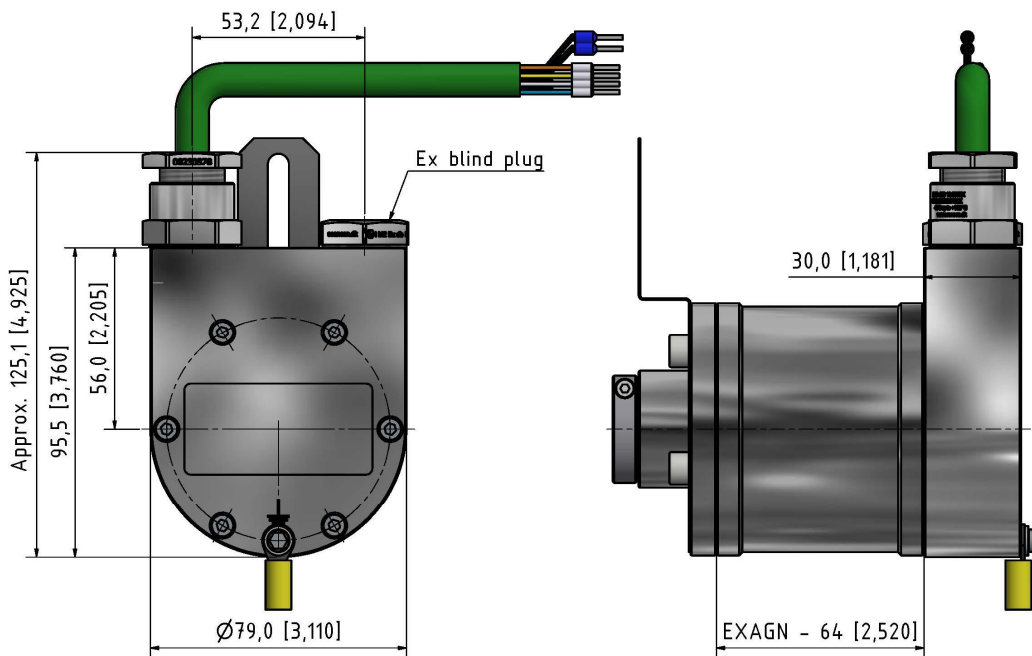

### Side Cable Takeout - EGB

mm (inches)

*Ex d certified cable gland included*

## Output Terminations

| Ethernet Cable |                                       |
|----------------|---------------------------------------|
| Function       | Wire Color                            |
| Vsup           | Black<br><i>(wire marked with #1)</i> |
| GND            | Black<br><i>(wire marked with #2)</i> |
| NC             | Black<br><i>(wire marked with #3)</i> |
| NC             | Black<br><i>(wire marked with #4)</i> |
| Tx +           | Yellow                                |
| Tx -           | Orange                                |
| Rx +           | White                                 |
| Rx -           | Blue                                  |

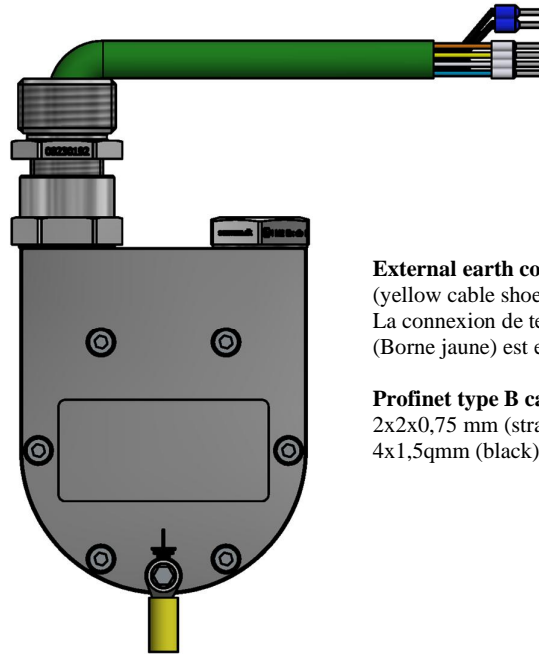

**External earth connection**  
 (yellow cable shoe) is 12-10 AWG.  
 La connexion de terre externe  
 (Borne jaune) est en 12-10 AWG.

**Profinet type B cable structure**  
 2x2x0,75 mm (stranded)  
 4x1,5qmm (black)

## Encoder Length

**Housing N (Table 1)**  
**(64 mm)**

**Total Encoder Length**

| End Cap | Clamping Flange B  | Clamping Flange C |
|---------|--------------------|-------------------|
| EGA/EGB | 103,5 mm (4,07 in) | 102 mm (4,02 in)  |

*End Cap + Face Mount + 64 mm = Total Encoder Length*

## Ordering Code

**Example: EXAGN – EM01B – 12 – 13 – H – AL – 01 – 66 – 01 – EGA – C – S1**

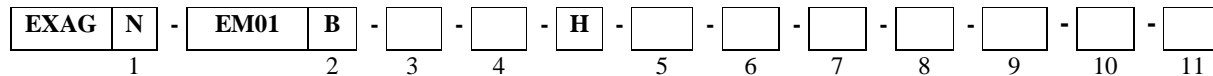

### 1. Housing

64 mm length ..... N  
 See Table 1

### 2. Interface

Ethernet Modbus/TCP+TCP/IP... **EM01**  
 Code ..... Binary **B**

### 3. Revolutions

Single Turn..... **00**  
 Multiturn 12 bits (4096) ..... **12**  
 Multiturn 14 bits (16384)..... **14**

### 4. Steps per revolution

13 bits (8192) (0.04°).....**13**  
 16 bits (65536) (0.005°).....**16**

### 5. Composition

Aluminum ..... **AL**  
 Stainless Steel\* ..... **VA**  
 Stainless Steel\*\* ..... **SA**

### 6. Hollow Shaft (diameter)

14 mm ..... **01**  
 16 mm *Face Mount B only*..... **02**  
 14 mm *Face mount B* ..... **03**  
 1 inch *Face mount B only*..... **04**

\* *ANSI 303*  
 \*\* *ANSI 316*

### 7. IP Rating

IP 64 ..... **64**  
 IP 65 ..... **65**  
 IP 66 ..... **66**  
 IP 67 ..... **67**  
 IP 68\* ..... **68**

\*1 meter/1 hour

### 8. Cable

Standard cable is 1 m..... **01**  
 Specify length..... **XX**

### 9. Cable Outlets

Side Standard..... **EGA**  
 Side Standard..... **EGB**

### 10. Flange

Clamping flange ..... **B**  
 Clamping flange ..... **C**

### 11. Accessory

Spring Coupling  
 1 hole *Flange C p/n 80131046*...**S1**  
 1 hole *FlangeB p/n 80131342*...**S2**