



EXAG – Profinet Removable End Cap

- Shaft Encoder – Ø78 mm
- Shaft: Ø10 mm, Ø12 mm
- Profinet
- Resolution up to 30 bits
- Removable End Cap for on-site modification
- ATEX, IECEx, EAC Ex and North America Class I Div. 2, Ex db IIC



Electrical Specifications		Mechanical Specifications	
Code:	Absolute - Binary	Material:	Housing: Aluminum or Stainless Steel Cap: Aluminum or Stainless Steel Shaft: Stainless Steel
Interface:	Profinet	Weight:	Aluminum: ~ 1600 gr (56,44 oz) Stainless Steel: ~ 3100 gr (109,35 oz)
Profile	Profidrive Profile 4.x, Encoder Profile 4.x	Bearing Life:	> 1,9 x 10 ¹⁰ revolutions at rated load
Resolution:	Max. 14 bit (16384) revolutions Max. 16 bit (65536) steps per rev.	Shaft Speed:	6.000 rpm (max.) IP 64 3.000 rpm (max.) IP 65, IP 66, IP 67
Device Addressing:	Programmable IP address and Network parameters	Starting Torque:	≤ 0,01 Nm at 25° C (no seal) ≤ 0,03 Nm at 25° C (with seal)
Transmission Rate:	10/100 Mbit	Rotor Mass Moment of Inertia:	42 gcm ² (5,95 x 10 ⁻⁴ oz-in-sec ²)
Supply Voltage:	10 to 30 Vdc (absolute limits)	Shaft Loads:	Axial: 60 N (13,50 lbs) max. Radial: 80 N (17,98 lbs) max.
Current Consumption:	Max. 230 mA with 10 Vdc Max. 100 mA with 24 Vdc	Environmental Specifications	
Power Consumption:	Max. 2.5 watts	Operating Temp.:	-40° to +70° C
Accuracy (INL):	±0.0220° (14-16 bit), ±0.0439° (≤13 bit)	Storage Temp.:	-40° to +70° C
MTTF:	65 years @ 40°C	Shock:	100g @ 11 ms
Electrical Protection:	Reverse polarity and over-voltage-peak protection	Vibration:	10g @ 10-2000 Hz
Noise Immunity:	EN61000-6-2	Bump:	10g @ 16 ms (1000 x 3 axis)
Emitted Interference:	EN 61000-6-4	Humidity:	98 % RH without condensation
		Enclosure Rating:	IP 64 / Nema 4 (approx.) IP 65 / Nema 5 (approx.) IP 66 / Nema 6 (approx.) IP 67 / Nema 6 (approx.) IP 68 (1hour/1 meter) / Nema 6P (approx.)

Certifications

ATEX:	Certificate No.: ITS09ATEX16867X II 2 G Ex db IIC T5 Gb II 2 D Ex tb IIIC T100°C Db -40°C ≤ Ta ≤ +70°C
IECEX:	Certificate No.: IECEX ITS 10.0016X Ex db IIC T5 Gb, Ex tb IIIC T100°C Db -40°C ≤ Ta ≤ +70°C
North America:	Certificate No: LR1192-5 Class I Division 2 Groups ABCD T5, Class II Division 2 Groups FG, Class I Zone 1A Ex db IIC T5 Gb, Ex db IIC T5 Gb, Zone 21 A Ex tb IIIC T100°C Db, Ex tb IIIC T100°C Db, Tamb= -40 °C to +70 °C
EAC Ex:	НАННО «ІСВЭ» No. EAЭC RU C-DK.AA87.B.00266/19 1Ex db IIC T5 Gb X, Ex tb IIIC T100°C Db X -40°C < T.amb < +70°C

Interface

PROFINET technology

PROFINET is an Industrial Ethernet standard merging plant automation with other enterprise IT resources.

It provides comparable functionality to PROFIBUS with techniques used by engineering, IT, and management personnel.

Established IT standards are employed as basis of communication: TCP, UDP, IP. XML is used as description language for device profiles (GSDML files).

Two ways of using PROFINET are available: PROFINET IO, similar to PROFIBUS DP as a distributed I/O system and PROFINET CBA as a modular component-based system for larger systems.

PROFINET offers scalable communication for different applications in industrial automation:

- PROFINET NRT (non real time) is suited for non-time-critical process automation with clock rates of roughly 100 msec.
- PROFINET RT (real time) offers a communication channel with optimized performance (10 msec clock rate) for most factory automation tasks
- PROFINET IRT (isochronous real time) employs special communication hardware to enable clock rates of less than 1 msec and a jitter precision of less than 1 μsec. This channel is mainly of use for motion control applications.

PROFINET IO uses a view of distributed I/O similar to PROFIBUS DP. IO controllers (e.g. PLCs) run an automation program, IO devices (e.g. absolute encoders) are remotely assigned field devices, and IO supervisors (e.g. programming devices) are used for commissioning and diagnostics.

The engineering of PROFINET IO is done similar to PROFIBUS. The field buses (i.e. Ethernet topologies) are assigned to control systems during configuration. The IO device is configured in the actual system based on the contents of its GSDML file.

After completion of the engineering the installer loads the data for the expansion into the IO controller (PLC) and the IO controller assumes data exchange with the IO device.

An IO device is addressed within PROFINET (and also possibly by external IT components) through its IP address.

Data can be exchanged from the IO controller to the IO device (and vice versa) cyclically (for process data). Apart from this, parameter data can be exchanged acyclically during engineering of the IO device or by the use of PLC programming blocks.

The GSDML file is necessary for installing the encoder. The **GSDML file can be downloaded [here](#)**

Output Terminations

Terminal connections

Position	Terminal
1	GND
2	Vsup
3	N.C.
4	N.C.
5	Rx -
6	Tx -
7	Rx +
8	Tx +

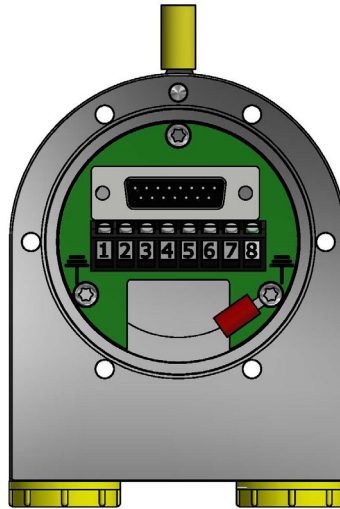

Internal earth connection

(red cable shoes) is 22-16 AWG.
La connexion à la terre interne (Borne rouge) est en 22-16 AWG.

External earth connection

(yellow cable shoe) is 12-10 AWG.
La connexion de terre externe (Borne jaune) est en 12-10 AWG.

Wire conductor size AWG 22-12,
 0.14 mm² – 2.5 mm².

*La taille de fil nominale est AWG 22-12,
 0.14 mm² – 2.5 mm²*

Face Mounts

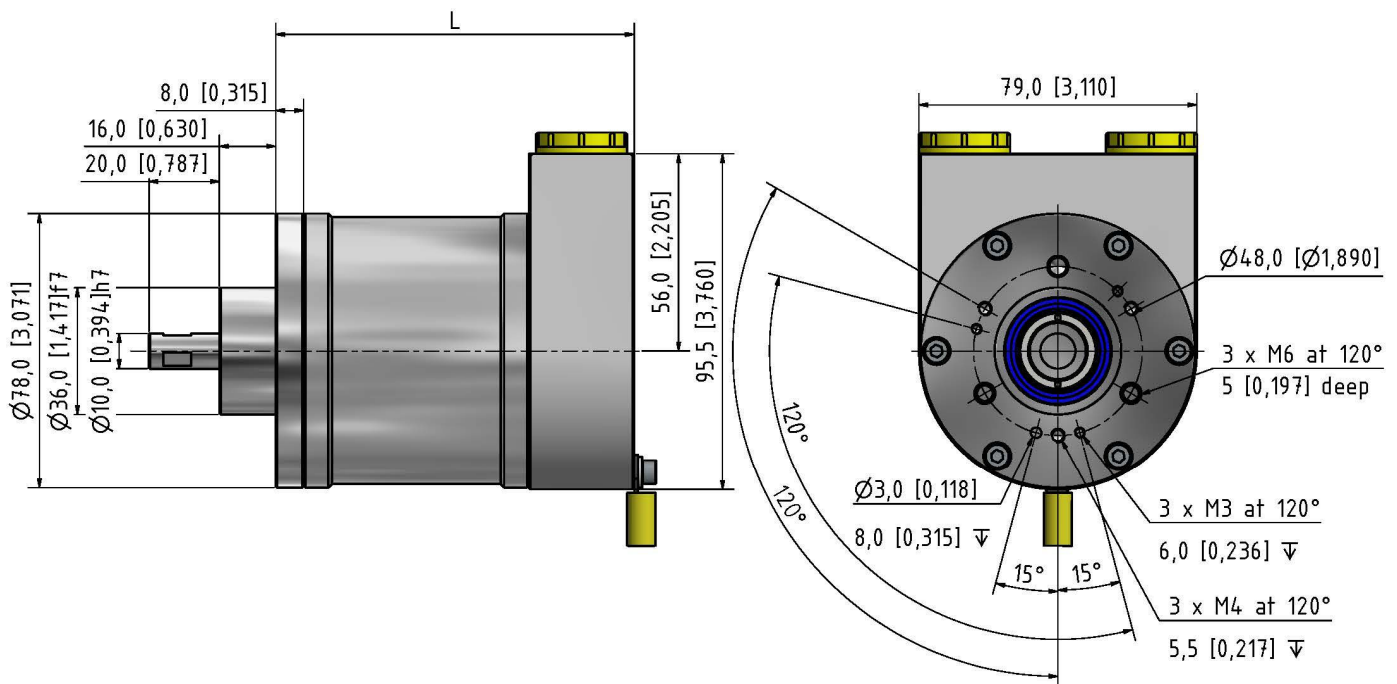

Face Mount C
 Clamping Flange

mm [inches]

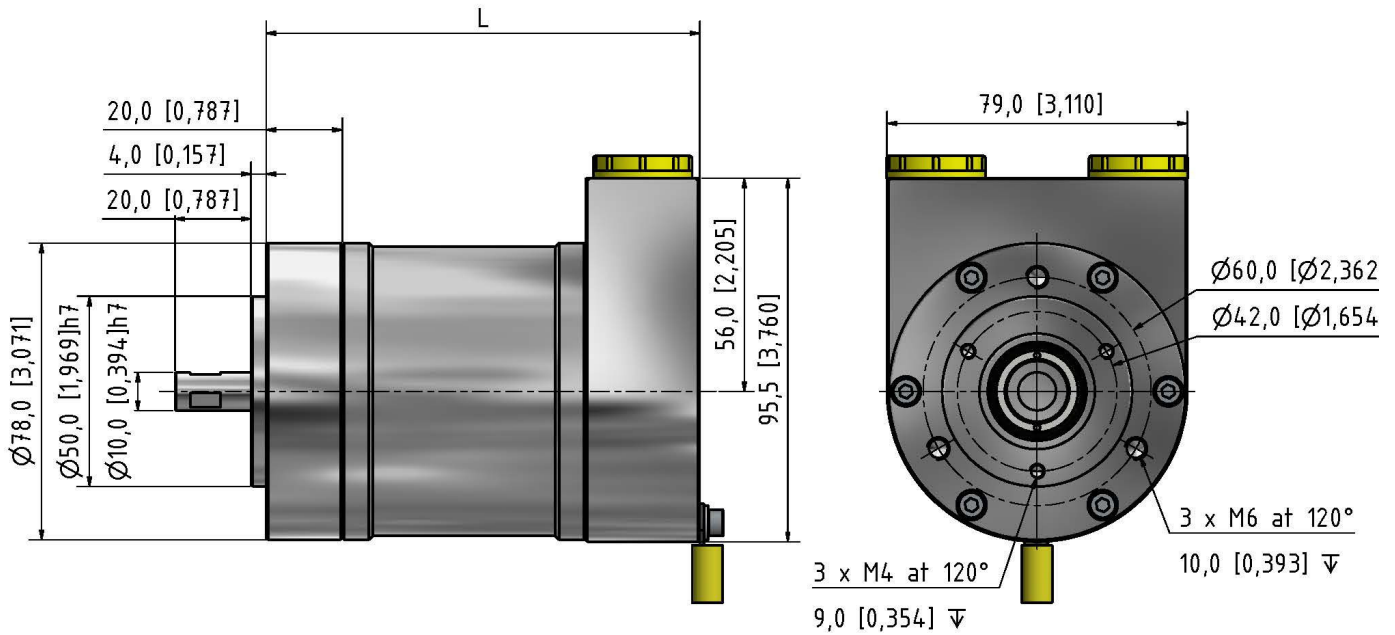

Face Mount S
Servo Flange

mm [inches]

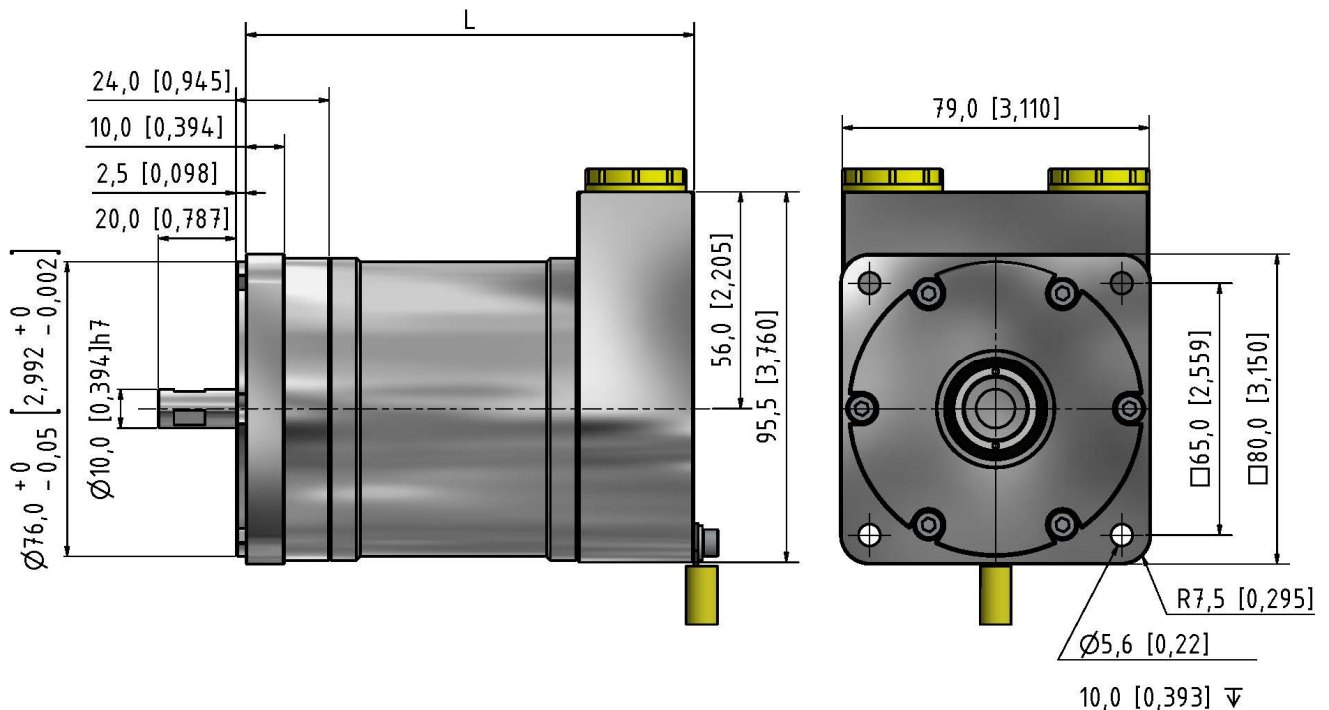

Face Mount Q
Square Flange

mm [inches]

VA/SA option only

End Caps with Cable Outlets

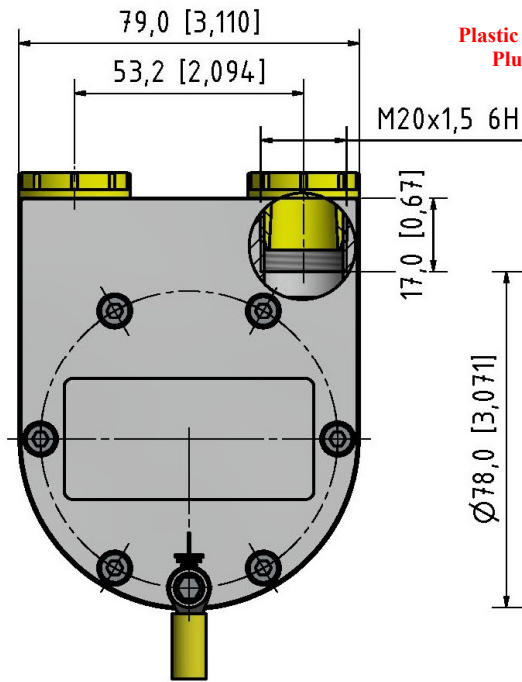

Plastic screw plug is for cable outlet protection during shipping and storage. Plug must be replaced by a suitably certified cable gland prior to use.

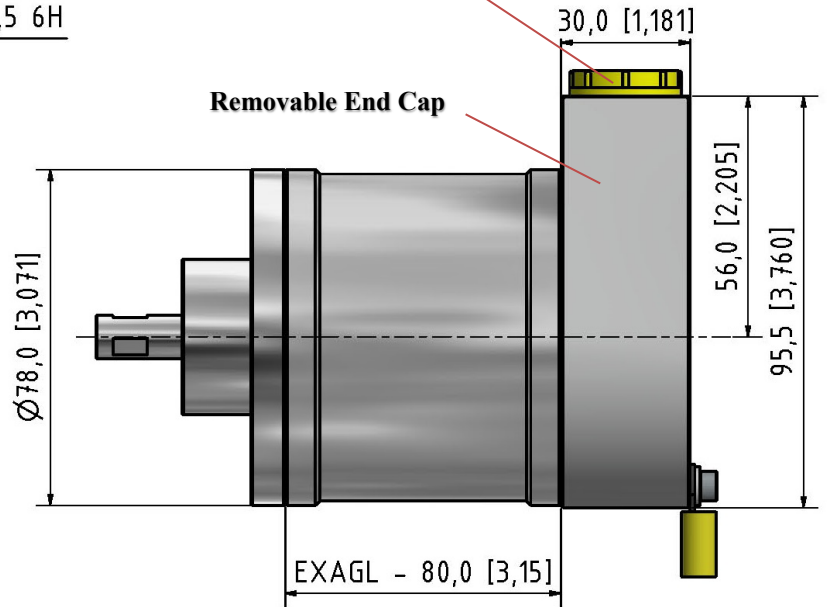

Side Standard End Cap (FZ)

mm [inches]

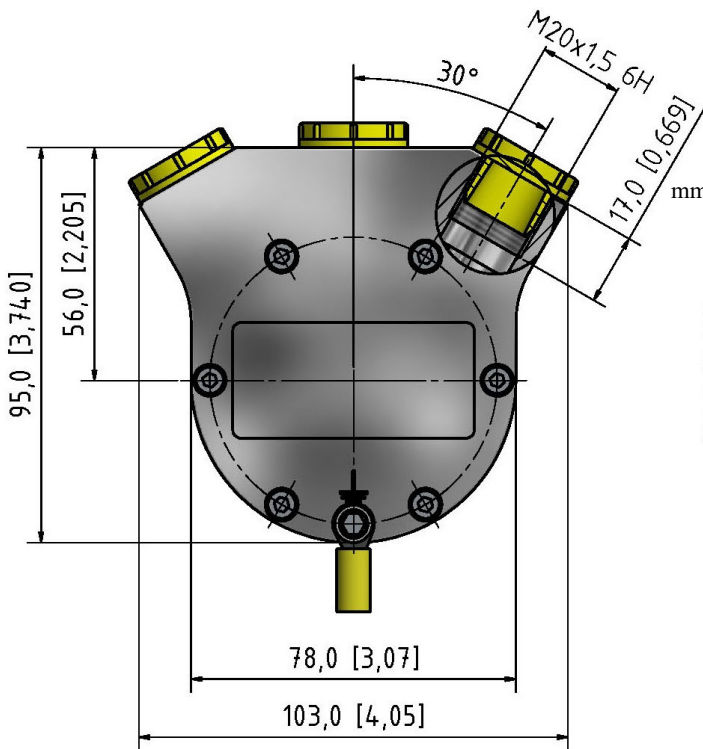

Plastic screw plug is for cable outlet protection during shipping and storage. Plug must be replaced by a suitably certified cable gland prior to use.

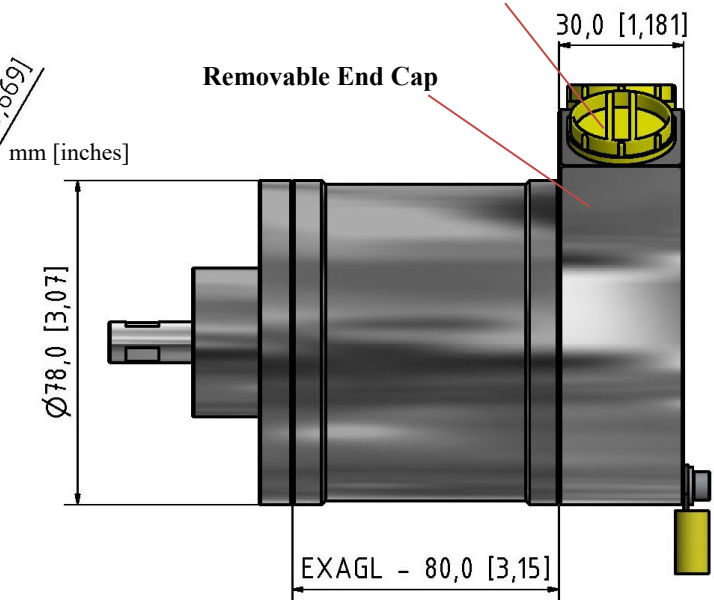

Side Standard End Cap (FE)

mm [inches]

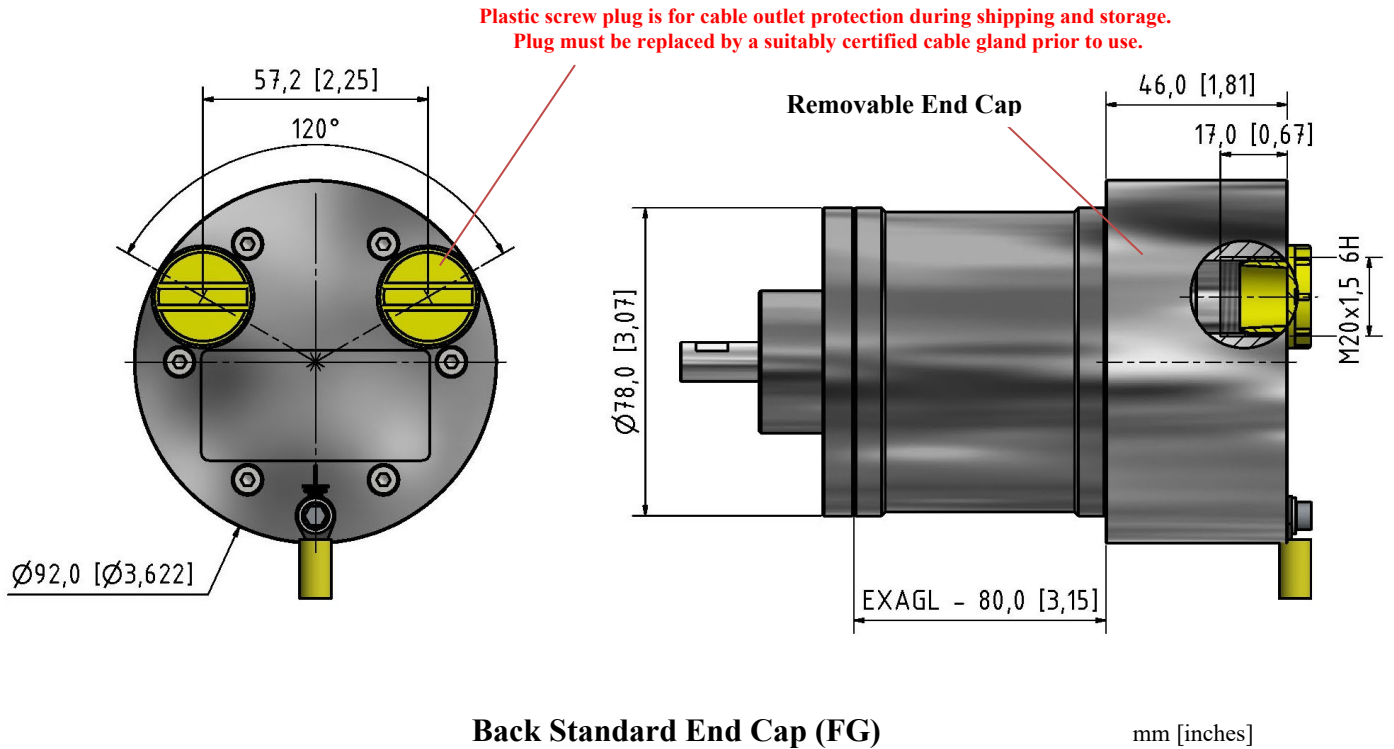

Encoder Length

Housing L (Table 1) (80 mm)

Total Encoder Length

End Cap	Face Mount		
	Clamping Flange C	Servo Flange S	Square Flange Q
FZ	118 mm (4,645 in)	130 mm (5,118 in)	131,5 mm (5,177 in)
FE	118 mm (4,645 in)	130 mm (5,118 in)	131,5 mm (5,177 in)
FG	134 mm (5,275 in)	146 mm (5,748 in)	147,5 mm (5,807 in)

End Cap + Face Mount + 80 mm = Total Encoder Length

Ordering Code

Example: EXAGL - EIY1B - 12 - 16 - A - AL - 01 - 66 - 00 - FZ - C - 00

EXAG	L	-	EIY1	B	-			-	A	-			-			-	00	-			-	00
	1			2		3	4			5	6	7		8	9	10			11			

1. Housing

80 mm length L
See Table 1

2. Interface

Vers. EIY1
Code Binary B

3. Revolutions

Single Turn.....00
Multiturn 12 bits (4096)12
Multiturn 14 bits (16384).....14

4. Steps per revolution

13 bits (8192) (0.04°).....13
16 bits (65536) (0.005°).....16

5. Composition

Aluminum AL
Stainless Steel* VA
Stainless Steel** SA

* AISI 303
** AISI 316

6. Shaft (diameter x length)

10 mm x 20 mm 2 flats, 8mm length..... 01
12 mm x 25 mm 2 flats, 8 mm length 02
10 mm x 20 mm 1 flat, 15 mm length ... 03

7. IP Rating

IP 64 64
IP 65 65
IP 66 66
IP 67 67
IP 68* 68

*1 meter/1 hour

8. Cable

No cable..... 00

9. Cable Outlets

Side Standard 2 outlets FZ
Side Triple 3 outlets..... FE
Back Round 2 outlets..... FG

10. Flange

Clamping flangeC
Synchro flangeS
Square VA/SA option only.....Q

11. Accessory

No accessory..... 00